

IVM AM-12 – AUTOMATIC FEEDER FOR HANDLE

Position n° 08

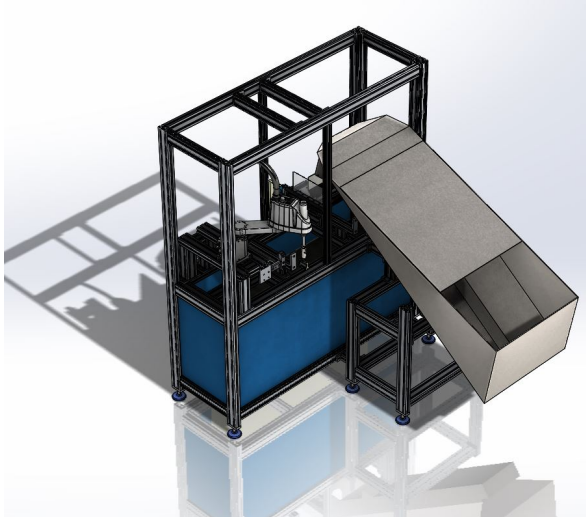

Automatic feeder for handles with robot and vision system. Load hopper made of inox steel with 200 liters capacity. Hourly productivity 1500 pieces with remote assistance available.

TECHNICAL DATA

Dimensions	1680x2000x2020
Weight	485 Kg
Operating voltage	380 V/ 50 Hz
Electrical consumption	4.2 A
Power absorbed	1.09 Kw
Single power cable (Not in assembly line)	5G2.5
Working pressure	6 Bar
Maximum pneumatic consumption	200 L/min
TWorking temperature	Min. 5°C Max. 40°C.
Humidity	Min. 8%, Max. 80%.
Noisiness	>80Db

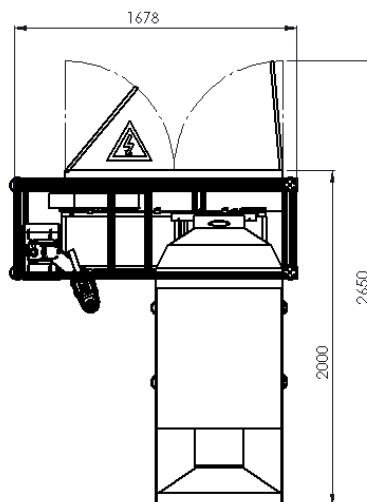
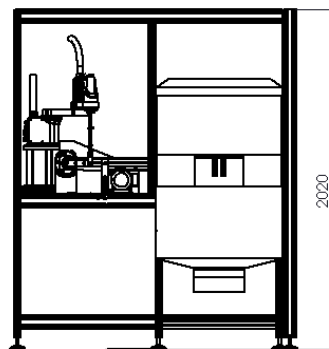

COMPONENTS

1	Elevator	1
2	Rear illuminated belt	1
3	Robot	1

